

# High Pressure Coolant Injection

1998–2009

## 1 INTRODUCTION

This report presents an unreliability evaluation of the high pressure coolant injection (HPCI) system at 25 U.S. commercial boiling water reactors (BWRs) listed in Table 1. For each plant the corresponding Standardized Plant Analysis Risk (SPAR) model (version model indicated in Table 1) was used in the yearly calculations. Demand, run hours, and failure data from fiscal year (FY) 1998 through FY 2009 for selected components in the HPCI were obtained from the Equipment Performance and Information Exchange (EPIX) database. Train unavailability data (outages from test or maintenance) were obtained from the Reactor Oversight Process (ROP) Safety System Unavailability (SSU) database (FY 1998–FY 2001) and the Mitigating Systems Performance Index (MSPI) database (FY 2002–FY 2009). Common-cause failure (CCF) data used in the models are from the 2005 update to the CCF database.

This report does not attempt to estimate basic event values for use in a probabilistic risk assessment (PRA). Suggested values for such use are presented in the report, *Industry-Average Performance for Components and Initiating Events at U.S. Commercial Nuclear Power Plants*, [NUREG/CR-6928](#) (Reference 1). Baseline HPCI unreliability results using basic event values from that report are summarized in Section 3. Trend results for HPCI (using system-specific data) are presented in Section 4. Similar to previous system study updates, Section 5 contains importance information (using the baseline results from Section 3), and Section 7 describes the HPCI.

Table 1. BWR plants with a HPCI system selected for the study.

Plant	Version	Plant	Version
Browns Ferry 1	3.21	Hope Creek	3.21
Browns Ferry 2	3.21	Limerick 1	3.21
Browns Ferry 3	3.21	Limerick 2	3.21
Brunswick 1	3.31	Monticello	3.31
Brunswick 2	3.31	Peach Bottom 2	3.31
Cooper	3.31	Peach Bottom 3	3.31
Dresden 2	3.31	Pilgrim	3.31
Dresden 3	3.31	Quad Cities 1	3.31
Duane Arnold	3.31	Quad Cities 2	3.31
Fermi 2	3.31	Susquehanna 1	3.31
FitzPatrick	3.31	Susquehanna 2	3.31
Hatch 1	3.31	Vermont Yankee	3.31
Hatch 2	3.31		

The HPCI model is evaluated using the transient flag set in the SPAR model. The transient flag set assumes all support systems are available and that the HPCI system is required to perform to mitigate the effects of the transient initiating event. All models include failures due to unavailability while in test or maintenance. Human error has not been included in the SPAR model logic. An overview of the trending

methods, glossary of terms, and abbreviations can be found in the [Overview and Reference](#) document on the Reactor Operational Experience Results and Databases web page.

Two modes of the models for the HPCI system are calculated. The HPCI start-only model is the SPAR HPCI model modified by setting all fail-to-run basic events to zero (False), setting all recovery events to False, setting the suction transfer to the torus to False, and setting all cooling basic events to False. The 8-hour mission model includes all basic events in the SPAR HPCI model.

## 2 SUMMARY OF FINDINGS

The results of this HPCI system unreliability study are summarized in this section. Of particular interest is the existence of any statistically significant<sup>1</sup> increasing trends. In this update, no statistically significant increasing trends were identified in the HPCI unreliability trend results. No statistically significant decreasing trends within the industry-wide estimates of HPCI system unreliability on a per fiscal year basis were identified.

The industry-wide HPCI start-only and 8-hour basic event group importances were evaluated and are shown in Figure 3. In both cases, the leading contributor to HPCI system unreliability is the HPCI turbine-driven pump group of basic events. The 8-hour model also has the injection and recovery as important segments.

## 3 INDUSTRY-WIDE UNRELIABILITY

The HPCI fault trees from the SPAR models were evaluated for each of the 25 operating U.S. commercial boiling water nuclear power plants with a HPCI system.

The industry-wide unreliability of the HPCI system has been estimated for two modes of operation. A failure to start (start-only) model and an 8-hour mission model were evaluated. The uncertainty distributions for HPCI show both plant design variability and parameter uncertainty from the industry-wide component failure data (1998–2002)<sup>2</sup>.

Table 2 shows the percentiles and mean of the aggregated sample data (Latin hypercube, 1000 samples for each model) collected from the uncertainty calculations of the HPCI fault trees in the SPAR models. The lower and upper bounds are based directly on the samples (Latin hypercube) from the uncertainty calculations in the SPAR models. For the industry-level results, the SPAR samples were combined into one large sample in order to determine the industry-level bounds, mean, and median.

---

<sup>1</sup> Statistically significant is defined in terms of the 'p-value.' A p-value is a probability indicating whether to accept or reject the null hypothesis that there is no trend in the data. P-values of less than or equal to 0.05 indicate that we are 95% confident that there is a trend in the data (reject the null hypothesis of no trend.) By convention, we use the "Michelin Guide" scale: p-value < 0.05 (statistically significant), p-value < 0.01 (highly statistically significant); p-value < 0.001 (extremely statistically significant).

<sup>2</sup> By using industry-wide component failure data, individual plant performance is not included in the distribution of results.

Table 2. Industry-wide unreliability values.

Model	Lower (5%)	Median	Mean	Upper (95%)
Start-Only	6.40E-03	2.13E-02	1.80E-02	4.76E-02
8-hour	1.43E-02	4.10E-02	3.56E-02	8.57E-02

## 4 INDUSTRY-WIDE TRENDS

The yearly (FY 1998–FY 2009) failure and demand or run time data were obtained from EPIX for the HPCI system. HPCI train maintenance unavailability data for trending are from the same time period, as reported in the ROP and EPIX. The component basic event uncertainty was calculated for the HPCI system components using the trending methods described in Section 1 and 2 of the [Overview and Reference](#) document. Table 6 and Table 7 show the yearly data values for each HPCI system specific component and failure mode combination that was varied in the model. These data were loaded into the HPCI system fault tree in each SPAR model with a HPCI system (see Table 1).

The trend charts show the results of varying component reliability data over time and updating generic, relatively-flat prior distributions using data for each year. In addition, for comparison, the calculated industry-wide system reliability this update (current SPAR/EPIX) is shown. Section 4 of the [Overview and Reference](#) link on the System Studies main web page provides more detailed discussion of the trending methods. In the lower left hand corner of the trend figures, the regression method is reported.

The components that were varied in the HPCI model are:

- HPCI turbine-driven pump start, run, and test and maintenance.
- HPCI motor-operated valve, fail to operate.

Figure 1 shows the trend in the start-only model unreliability. Table 4 shows the data points for Figure 1. No statistically significant decreasing trends within the industry-wide estimates of HPCI system unreliability (start-only) on a per fiscal year basis were identified.

Figure 2 shows the trend in the 8-hour mission unreliability. Table 5 shows the data points for Figure 2. No statistically significant decreasing trends within the industry-wide estimates of HPCI system unreliability (8-hour mission) on a per fiscal year basis were identified.

The uptick in the start-only (Figure 1) and to a lesser degree the 8-hour mission (Figure 2) reliability estimates for 2007 is attributable to an increase in the observed HPCI TDP fail-to-start events in 2007 (four fail-to-start events). See the TDP 2007 update, Table 4 to see the HPCI failure summary. The four events occurred at two plants. Two of those failures involved the governor, one the trip-stop valve, and one where water got into the lubricating oil system.

## 5 BASIC EVENT GROUP IMPORTANCES

The HPCI basic event group Fussell-Vesely importances were calculated for the start-only and 8-hour modes for each plant using the industry-wide data (1998–2002). These basic event group importances were then averaged across all plants to represent an industry-wide basic event group importance. The industry-wide HPCI start-only and 8-hour basic event group importances are shown in Figure 3.

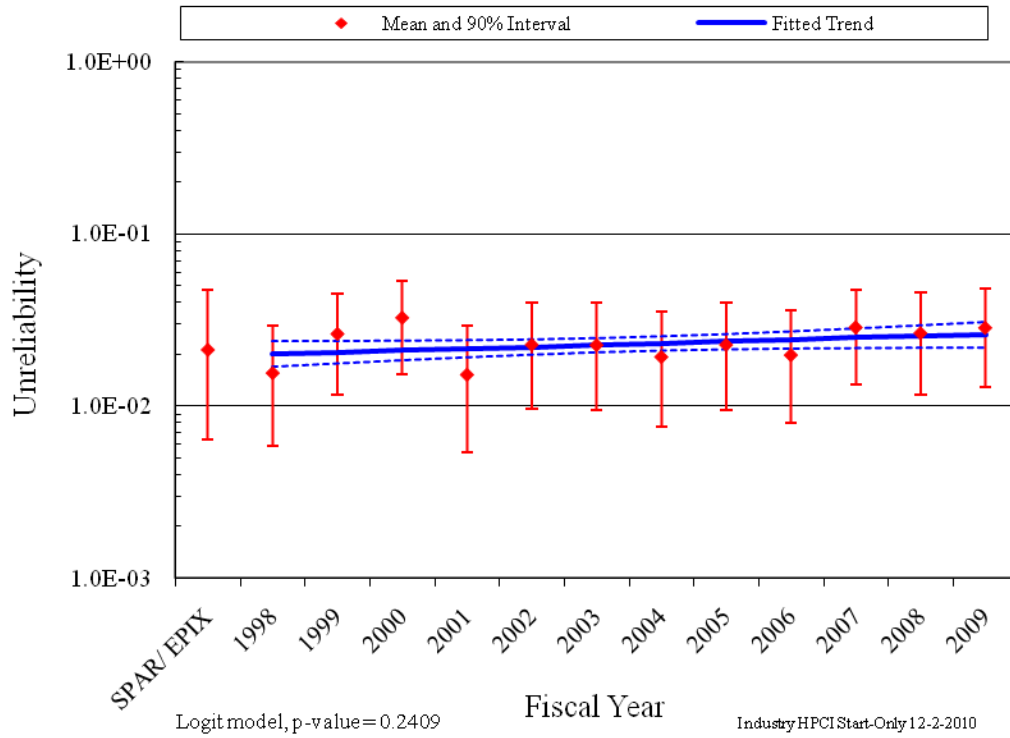

Figure 1. Trend of HPCI system unreliability (start-only model), as a function of fiscal year.

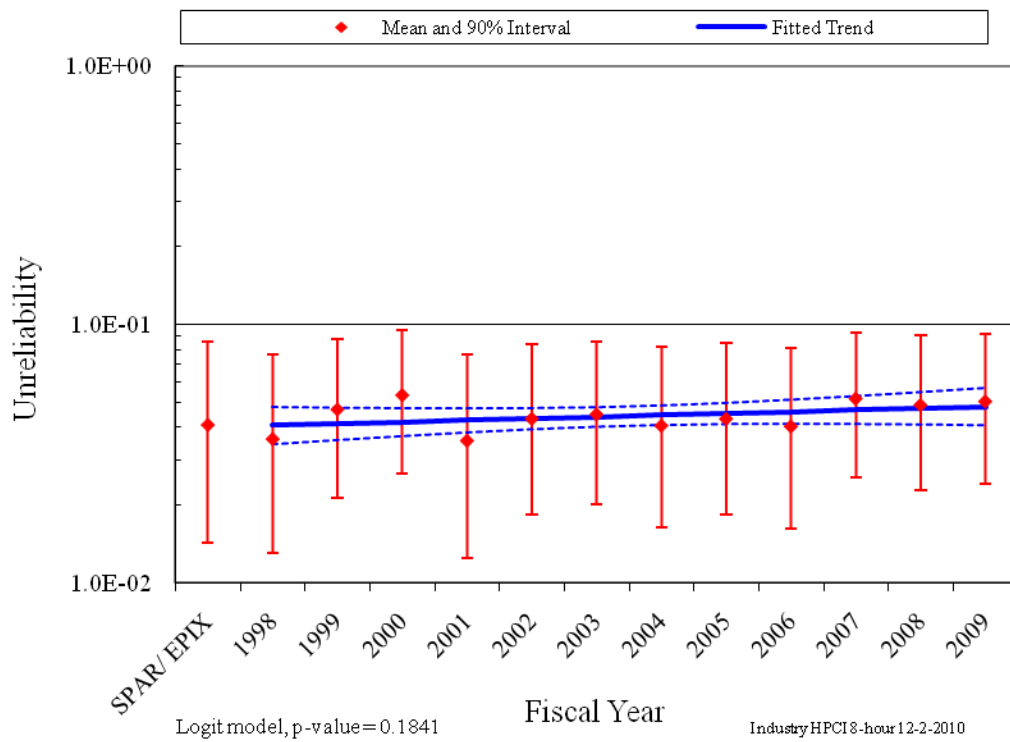

Figure 2. Trend of HPCI system unreliability (8-hour model), as a function of fiscal year.

In both cases, the leading contributor to HPCI system unreliability is the HPCI turbine-driven pump group of basic events. The 8-hour model also has the injection and recovery as important segments. For more discussion on the HPCI turbine-driven pumps, see the turbine-driven pump component reliability study at [NRC Reactor Operational Experience Results and Databases](#). Table 3 shows the SPAR model HPCI importance groups and their descriptions.

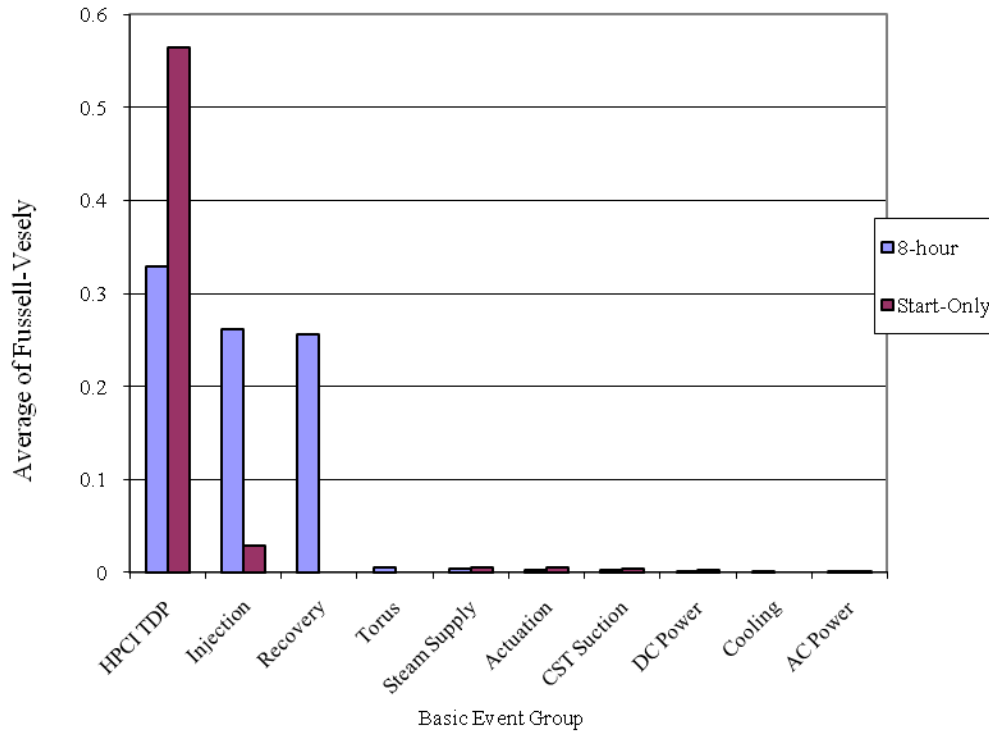

Figure 3. HPCI basic event group importances.

Table 3. HPCI model basic event importance group descriptions.

Group	Description
AC Power	The ac buses and circuit breakers that supply power to the service water pumps and the HPCI motor-operated valves.
Actuation	ESF actuation circuitry.
Cooling	The pumps, valves, and heat exchangers that provide heat removal to the HPCI turbine-driven pump.
CST Suction	Suction path and condensate storage tank.
DC Power	The batteries and battery chargers that supply power to the HPCI turbine-driven pump control circuitry.
HPCI TDP	All basic events associated with the turbine-driven pumps. The start, run, common-cause, and test and maintenance are included in the group of basic events.
Injection	The motor-operated valves and check valves in the HPCI injection path.
Recovery	Recovery of the HPCI turbine fail-to-start.
Special	Various events used in the models that are not directly associated with the HPCI system.
Steam Supply	The steam supply valves to the HPCI turbine.
Torus	The suppression pool motor-operated valves, check valves, and strainers required when a need to transfer to the suppression pool (torus) occurs.

## 6 DATA TABLES

Table 4. Plot data for HPCI start-only trend, Figure 1.

FY/Source	Regression Curve Data Points			Plot Trend Error Bar Points		
	Mean	Lower (5%)	Upper (95%)	Lower (5%)	Upper (95%)	Mean
SPAR/ EPIX				6.40E-03	4.76E-02	2.13E-02
1998	2.00E-02	1.69E-02	2.38E-02	5.87E-03	2.95E-02	1.56E-02
1999	2.05E-02	1.76E-02	2.38E-02	1.17E-02	4.46E-02	2.64E-02
2000	2.10E-02	1.85E-02	2.39E-02	1.53E-02	5.29E-02	3.27E-02
2001	2.15E-02	1.92E-02	2.41E-02	5.44E-03	2.93E-02	1.53E-02
2002	2.21E-02	2.00E-02	2.44E-02	9.57E-03	4.00E-02	2.28E-02
2003	2.26E-02	2.06E-02	2.48E-02	9.53E-03	3.99E-02	2.27E-02
2004	2.32E-02	2.11E-02	2.54E-02	7.60E-03	3.54E-02	1.94E-02
2005	2.37E-02	2.15E-02	2.62E-02	9.56E-03	4.00E-02	2.28E-02
2006	2.43E-02	2.17E-02	2.72E-02	8.05E-03	3.58E-02	1.99E-02
2007	2.49E-02	2.19E-02	2.84E-02	1.33E-02	4.77E-02	2.88E-02
2008	2.55E-02	2.20E-02	2.96E-02	1.15E-02	4.54E-02	2.66E-02
2009	2.62E-02	2.20E-02	3.10E-02	1.30E-02	4.77E-02	2.86E-02

Table 5. Plot data for HPCI 8-hour trend, Figure 2.

FY/Source	Regression Curve Data Points			Plot Trend Error Bar Points		
	Mean	Lower (5%)	Upper (95%)	Lower (5%)	Upper (95%)	Mean
SPAR/ EPIX				1.43E-02	8.57E-02	4.10E-02
1998	4.08E-02	3.45E-02	4.82E-02	1.31E-02	7.66E-02	3.62E-02
1999	4.14E-02	3.57E-02	4.79E-02	2.14E-02	8.82E-02	4.70E-02
2000	4.21E-02	3.70E-02	4.77E-02	2.65E-02	9.50E-02	5.34E-02
2001	4.27E-02	3.82E-02	4.77E-02	1.25E-02	7.61E-02	3.56E-02
2002	4.34E-02	3.93E-02	4.78E-02	1.84E-02	8.43E-02	4.33E-02
2003	4.40E-02	4.02E-02	4.82E-02	2.01E-02	8.59E-02	4.50E-02
2004	4.47E-02	4.08E-02	4.89E-02	1.65E-02	8.15E-02	4.07E-02
2005	4.54E-02	4.12E-02	5.00E-02	1.83E-02	8.43E-02	4.33E-02
2006	4.61E-02	4.13E-02	5.14E-02	1.62E-02	8.12E-02	4.05E-02
2007	4.68E-02	4.12E-02	5.31E-02	2.55E-02	9.32E-02	5.18E-02
2008	4.75E-02	4.10E-02	5.49E-02	2.30E-02	9.03E-02	4.90E-02
2009	4.82E-02	4.08E-02	5.69E-02	2.43E-02	9.19E-02	5.05E-02

Table 6. Basic event reliability trending data.

Failure Mode	Component	Year	Number of Failures	Demands/Run Hours	Bayesian Update			Distribution
					Mean	Post A	Post B	
FTOC	AOV	1998	0	112.8	1.06E-03	1	945.1	Beta
FTOC	AOV	1999	0	112.6	1.06E-03	1	944.9	Beta
FTOC	AOV	2000	0	112.6	1.06E-03	1	944.9	Beta
FTOC	AOV	2001	0	113.8	1.06E-03	1	946.1	Beta
FTOC	AOV	2002	0	113.5	1.06E-03	1	945.9	Beta
FTOC	AOV	2003	0	113.5	1.06E-03	1	945.9	Beta
FTOC	AOV	2004	0	114.5	1.06E-03	1	946.8	Beta
FTOC	AOV	2005	0	113.5	1.06E-03	1	945.9	Beta
FTOC	AOV	2006	0	113.5	1.06E-03	1	945.9	Beta
FTOC	AOV	2007	0	113.5	1.06E-03	1	945.9	Beta
FTOC	AOV	2008	0	113.5	1.06E-03	1	945.9	Beta
FTOC	AOV	2009	0	113.5	1.06E-03	1	945.9	Beta
FTOC	MOV	1998	4	2720.3	1.33E-03	5.2	3915.1	Beta
FTOC	MOV	1999	3	2591.6	1.11E-03	4.2	3787.4	Beta
FTOC	MOV	2000	2	2674.1	8.26E-04	3.2	3870.9	Beta
FTOC	MOV	2001	2	2621.9	8.37E-04	3.2	3818.7	Beta
FTOC	MOV	2002	2	2634.5	8.35E-04	3.2	3831.3	Beta
FTOC	MOV	2003	2	2798.0	8.00E-04	3.2	3994.8	Beta
FTOC	MOV	2004	2	2686.4	8.23E-04	3.2	3883.2	Beta
FTOC	MOV	2005	2	2736.1	8.13E-04	3.2	3932.9	Beta
FTOC	MOV	2006	4	2698.7	1.33E-03	5.2	3893.5	Beta
FTOC	MOV	2007	9	2774.1	2.57E-03	10.2	3963.9	Beta
FTOC	MOV	2008	1	2633.4	5.74E-04	2.2	3831.2	Beta
FTOC	MOV	2009	7	2683.4	2.11E-03	8.2	3875.2	Beta
FTR	TDP	1998	0	181.2	6.83E-05	0.5	7324.0	Gamma
FTR	TDP	1999	0	195.2	6.81E-05	0.5	7338.1	Gamma
FTR	TDP	2000	0	171.8	6.84E-05	0.5	7314.7	Gamma
FTR	TDP	2001	0	172.8	6.83E-05	0.5	7315.6	Gamma
FTR	TDP	2002	0	163.4	6.84E-05	0.5	7306.3	Gamma
FTR	TDP	2003	2	155.1	3.43E-04	2.5	7298.0	Gamma
FTR	TDP	2004	1	146.4	2.06E-04	1.5	7289.2	Gamma
FTR	TDP	2005	0	148.0	6.86E-05	0.5	7290.9	Gamma
FTR	TDP	2006	0	129.4	6.88E-05	0.5	7272.2	Gamma
FTR	TDP	2007	2	133.1	3.44E-04	2.5	7275.9	Gamma
FTR	TDP	2008	2	131.6	3.44E-04	2.5	7274.4	Gamma
FTR	TDP	2009	1	233.8	2.03E-04	1.5	7376.7	Gamma
FTR<1H	TDP	1998	0	216.6	1.49E-03	0.8	536.6	Gamma
FTR<1H	TDP	1999	0	202.7	1.53E-03	0.8	522.7	Gamma
FTR<1H	TDP	2000	2	210.8	5.28E-03	2.8	530.8	Gamma
FTR<1H	TDP	2001	1	178.6	3.61E-03	1.8	498.6	Gamma
FTR<1H	TDP	2002	0	191.6	1.56E-03	0.8	511.6	Gamma
FTR<1H	TDP	2003	1	192.8	3.51E-03	1.8	512.8	Gamma
FTR<1H	TDP	2004	0	174.4	1.62E-03	0.8	494.4	Gamma
FTR<1H	TDP	2005	0	191.0	1.57E-03	0.8	511.0	Gamma
FTR<1H	TDP	2006	0	179.6	1.60E-03	0.8	499.6	Gamma
FTR<1H	TDP	2007	1	188.6	3.54E-03	1.8	508.6	Gamma
FTR<1H	TDP	2008	1	185.3	3.56E-03	1.8	505.3	Gamma
FTR<1H	TDP	2009	0	182.3	1.59E-03	0.8	502.3	Gamma
FTS	TDP	1998	0	216.6	1.46E-03	0.4	273.4	Beta
FTS	TDP	1999	3	202.7	1.31E-02	3.4	256.4	Beta
FTS	TDP	2000	5	210.8	2.02E-02	5.4	262.5	Beta

Failure Mode	Component	Year	Number of Failures	Demands/Run Hours	Bayesian Update			
					Mean	Post A	Post B	Distribution
FTS	TDP	2001	0	178.6	1.70E-03	0.4	235.3	Beta
FTS	TDP	2002	2	191.6	9.65E-03	2.4	246.3	Beta
FTS	TDP	2003	2	192.8	9.60E-03	2.4	247.6	Beta
FTS	TDP	2004	1	174.4	6.05E-03	1.4	230.2	Beta
FTS	TDP	2005	2	191.0	9.67E-03	2.4	245.8	Beta
FTS	TDP	2006	1	179.6	5.91E-03	1.4	235.3	Beta
FTS	TDP	2007	3	188.6	1.38E-02	3.4	242.4	Beta
FTS	TDP	2008	3	185.3	1.40E-02	3.4	239.1	Beta
FTS	TDP	2009	3	182.3	1.42E-02	3.4	236.1	Beta
SO	AOV	1998	0	96360	1.88E-07	0.3	1596360	Gamma
SO	AOV	1999	0	96360	1.88E-07	0.3	1596360	Gamma
SO	AOV	2000	0	96360	1.88E-07	0.3	1596360	Gamma
SO	AOV	2001	0	96360	1.88E-07	0.3	1596360	Gamma
SO	AOV	2002	0	96360	1.88E-07	0.3	1596360	Gamma
SO	AOV	2003	0	96360	1.88E-07	0.3	1596360	Gamma
SO	AOV	2004	0	96360	1.88E-07	0.3	1596360	Gamma
SO	AOV	2005	0	96360	1.88E-07	0.3	1596360	Gamma
SO	AOV	2006	0	96360	1.88E-07	0.3	1596360	Gamma
SO	AOV	2007	0	96360	1.88E-07	0.3	1596360	Gamma
SO	AOV	2008	0	96360	1.88E-07	0.3	1596360	Gamma
SO	AOV	2009	0	96360	1.88E-07	0.3	1596360	Gamma
SO	MOV	1998	1	2295120	1.01E-07	1.5	14795120	Gamma
SO	MOV	1999	0	2286360	3.38E-08	0.5	14786360	Gamma
SO	MOV	2000	0	2286360	3.38E-08	0.5	14786360	Gamma
SO	MOV	2001	0	2286360	3.38E-08	0.5	14786360	Gamma
SO	MOV	2002	0	2286360	3.38E-08	0.5	14786360	Gamma
SO	MOV	2003	0	2286360	3.38E-08	0.5	14786360	Gamma
SO	MOV	2004	0	2295120	3.38E-08	0.5	14795120	Gamma
SO	MOV	2005	0	2295120	3.38E-08	0.5	14795120	Gamma
SO	MOV	2006	0	2295120	3.38E-08	0.5	14795120	Gamma
SO	MOV	2007	1	2295120	1.01E-07	1.5	14795120	Gamma
SO	MOV	2008	0	2295120	3.38E-08	0.5	14795120	Gamma
SO	MOV	2009	0	2295120	3.38E-08	0.5	14795120	Gamma

Table 7. Basic event UA trending data.

Failure Mode	Component	Year	UA Hours	Critical Hours	Bayesian Update			
					Mean	Post A	Post B	Distribution
UA	TDP	1998	1721.37	136702	1.34E-02	1.9	143.0	Beta
UA	TDP	1999	2235.623	191025	1.16E-02	1.9	160.9	Beta
UA	TDP	2000	2366.732	195332	1.21E-02	1.5	121.8	Beta
UA	TDP	2001	1724.847	198783	8.75E-03	0.7	78.9	Beta
UA	TDP	2002	2194.466	197131	1.12E-02	1.4	125.3	Beta
UA	TDP	2003	2630.086	194670	1.35E-02	3.1	223.9	Beta
UA	TDP	2004	2159.717	199136	1.09E-02	1.0	92.8	Beta
UA	TDP	2005	1500.275	192534	7.96E-03	1.6	201.0	Beta
UA	TDP	2006	1666.3	198637	8.52E-03	1.6	188.8	Beta
UA	TDP	2007	2702.14	196123	1.40E-02	1.5	103.4	Beta
UA	TDP	2008	2576.77	198317	1.29E-02	0.5	41.5	Beta
UA	TDP	2009	2302.25	194422	1.19E-02	1.7	138.1	Beta



Table 8. Failure mode acronyms.

Failure Mode	Failure Mode Description
FTLR	Fail to Load/Run
FTOC	Fail to Operate
FTR	Fail to Run
FTR<1H	Fail to Run <1H
FTS	Fail to Start
SO	Spurious Operation
UA	Unavailability (Maintenance or State of another component)

## 7 HPCI SYSTEM DESCRIPTION

The HPCI system is a single-train system that provides a reliable source of high-pressure coolant for cases where there is a loss of normal core coolant inventory. Figure 4 provides a simplified schematic diagram of the system.

The HPCI system consists of a steam turbine-driven pump, valves, and valve operators, and associated piping, including that from the normal and alternate pump suction sources and the pump discharge up to the penetration of the main feedwater line. For this study, the part of the main feedwater line from the check valve upstream of the HPCI connection to the reactor vessel, including the check valve, was considered part of the HPCI system. The steam turbine-driven pump includes all steam piping from the main steam line penetration to the turbine, and turbine exhaust piping to the suppression pool, valves and valve operators, gland sealing steam, and the turbine auxiliary oil system.

The HPCI system is actuated by either a low reactor water level or a high drywell pressure. Initially the system operates in an open loop mode, taking suction from the condensate storage tank (CST) and injecting water into the reactor pressure vessel (RPV) via one of the main feedwater lines. When the level in the CST reaches a low-level set point, the HPCI pump suction is aligned to the suppression pool. To maintain RPV level after the initial recovery, the HPCI system is placed in manual control, which may involve controlling turbine speed, diverting flow through minimum-flow or test lines, cycling the injection motor-operated valve (MOV), or complete stop-start cycles.

The HPCI system is also manually used to help control RPV pressure following a transient. Although this is not part of the ECCS design function, it is depended on, in approximately 90% of the PRA/IPEs. However, only approximately 10% of the PRA/IPEs that depend on this function model the pressure control operation. In this mode, the turbine-driven pump is operated manually with the injection valve closed and the full-flow test-line MOV open. Turbine operation with the injection line isolated and the test line open allows the turbine to draw steam from the RPV, thereby reducing RPV pressure. Operation of the system in the pressure control mode may also occur with intermittent injection of coolant to the RPV. As steam is being drawn off the RPV, the RPV water inventory is reduced, resulting in the need for level restoration. When level restoration is required, the injection valve is opened and the test-line MOV is closed. Upon restoration of RPV water inventory, the system is returned to the pressure control line-up. This cycling between injection and pressure control can be repeated as necessary.

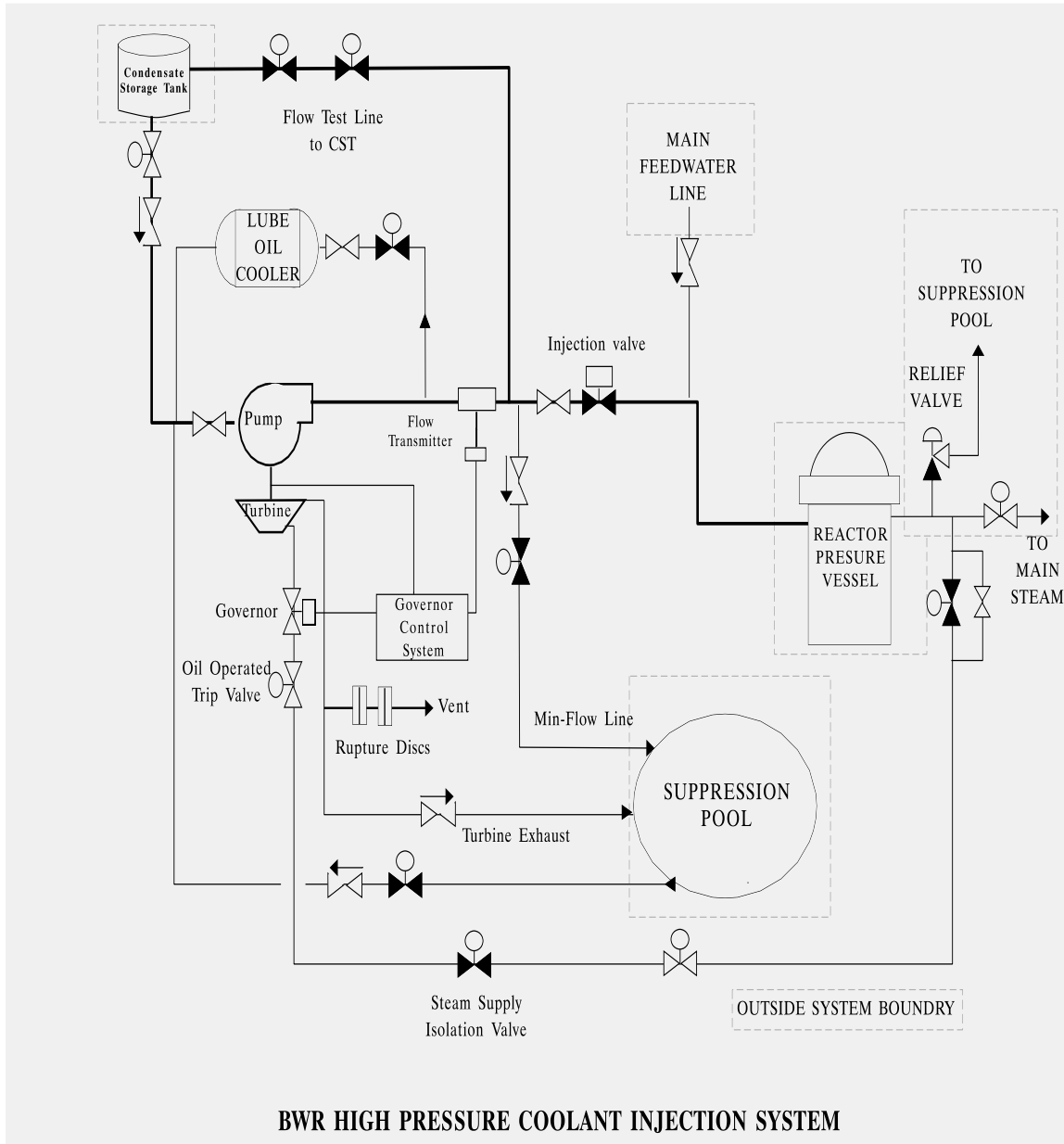

Figure 4. HPCI system diagram.

## 8 REFERENCE

1. S.A. Eide, et al, *Industry-Average Performance for Components and Initiating Events at U.S. Commercial Nuclear Power Plants*, U.S. Nuclear Regulatory Commission, NUREG/CR-6928, February 2007.