

System Study: High-Pressure Core Spray 1998–2018

Zhegang Ma
Kellie J. Kvarfordt
John A. Schroeder
Thomas E. Wierman

December 2019



The INL is a U.S. Department of Energy National Laboratory
operated by Battelle Energy Alliance

NOTICE

This information was prepared as an account of work sponsored by an agency of the U.S. Government. Neither the U.S. Government nor any agency thereof, nor any of their employees, makes any warranty, express or implied, or assumes any legal liability or responsibility for any third party's use, or the results of such use, of any information, apparatus, product, or process disclosed herein, or represents that its use by such third party would not infringe privately owned rights. The views expressed herein are not necessarily those of the U.S. Nuclear Regulatory Commission.

**System Study:
High-Pressure Core Spray
1998–2018**

**Zhegang Ma¹, Kellie J. Kvarfordt¹,
John A. Schroeder², Thomas E. Wierman²**

Update Completed December 2019

**¹Idaho National Laboratory, Risk Assessment and Management
Services Department, Idaho Falls, Idaho 83415**

**²Schroeder Incorporated, 3945 Wise Owl Way, Island Park, Idaho
83429**

<http://www.inl.gov>

**Prepared for the
Division of Risk Assessment
Office of Nuclear Regulatory Research
U.S. Nuclear Regulatory Commission
NRC Agreement Number NRC-HQ-14-D-0018**

ABSTRACT

This report presents an unreliability evaluation of the high-pressure core spray (HPCS) at eight U.S. commercial boiling water reactors. Demand, run hours, and failure data from 1998 through 2018 for selected components were obtained from the Institute of Nuclear Power Operations (INPO) Industry Reporting and Information System (IRIS), formerly the INPO Consolidated Events Database (ICES). The unreliability results are trended for the most recent 10-year period while yearly estimates for system unreliability are provided for the entire active period. No statistically significant increasing or decreasing trends were identified in the HPCS results.

CONTENTS

ABSTRACT.....	iii
ACRONYMS.....	vii
1. INTRODUCTION	1
2. SUMMARY OF FINDINGS	3
3. INDUSTRY-WIDE UNRELIABILITY	4
4. INDUSTRY-WIDE TRENDS	5
5. BASIC EVENT GROUP IMPORTANCES	7
6. DATA TABLES	10
7. SYSTEM DESCRIPTION	19
8. REFERENCES.....	22

FIGURES

Figure 1. Trend of HPCS system unreliability (start-only model), as a function of fiscal year.....	6
Figure 2. Trend of HPCS system unreliability (8-hour model), as a function of fiscal year.	6
Figure 3. HPCS basic event group importances.....	8
Figure 4. Simplified schematic of the HPCS system.	21

TABLES

Table 1. BWR plants with a HPCI system selected for the study.....	2
Table 2. Industry-wide unreliability values.	4
Table 3. HPCS model basic event importance group descriptions.	9
Table 4. Plot data for HPCI start-only trend, Figure 1.....	10
Table 5. Plot data for HPCS 8-hour trend, Figure 2.....	11

Table 6. Basic event reliability trending data. 12

Table 7. Basic event UA trending data. 17

Table 8. Failure mode acronyms..... 18

Table 9. BWR plants with an HPCS system..... 19

ACRONYMS

ADS	automatic depressurization system
BWR	boiling water reactor
CCF	common-cause failure
EPIX	Equipment Performance and Information Exchange
FTOC	fail to open/close
FTOP	fail to operate
FTR	fail to run
FTR>1H	fail to run more than one hour (standby)
FTR<1H	fail to run less than one hour (after start)
FTS	fail to start
HPCI	high-pressure coolant injection
HPCS	high-pressure core spray
ICES	INPO Consolidated Events Database
INPO	Institute of Nuclear Power Operations
IRIS	Industry Reporting and Information System
LOCA	loss-of-coolant accident
LOOP	loss-of-offsite power
LPCI	low-pressure coolant injection
LPCS	low-pressure core spray
MDP	motor-driven pump
MOV	motor-operated valve
MSPI	Mitigating Systems Performance Index
NRC	Nuclear Regulatory Commission
PRA	probabilistic risk assessment
RCIC	reactor core isolation cooling
ROP	Reactor Oversight Process
RPV	reactor pressure vessel
SO	spurious operation
SPAR	standardized plant analysis risk
SSU	safety system unavailability
UA	unavailability (maintenance or state of another component)

System Study: High-Pressure Core Spray 1998–2018

1. INTRODUCTION

This report presents an unreliability evaluation of the high-pressure core spray (HPCS) systems at the eight U.S. commercial boiling water reactors (BWRs) listed in Table 1. For each plant, the corresponding Standardized Plant Analysis Risk (SPAR) model (version model indicated in Table 1) was used in the yearly calculations. Demand, run hours, and failure data from 1998 through 2018 for selected components in the HPCS system were obtained from the Institute of Nuclear Power Operations (INPO) Industry Reporting and Information System (IRIS), formerly the INPO Consolidated Events Database (ICES) and the Equipment Performance and Information Exchange Database (EPIX). Train unavailability data (outages from test or maintenance) were obtained from the Reactor Oversight Process (ROP) Safety System Unavailability (SSU) database (1998 through 2001) and the Mitigating Systems Performance Index (MSPI) database (2002 through 2018). Common-cause failure (CCF) data used in the models are from the 2010 update to the CCF database. The system unreliability results are trended for the most recent 10-year period while yearly estimates for system unreliability are provided for the entire active period.

This report does not attempt to estimate basic event values for use in a probabilistic risk assessment (PRA). Suggested values for such use are presented in the 2015 Component Reliability Update [1], which is an update to NUREG/CR-6928 [2] and the 2010 Component Reliability Update [3]. Baseline HPCS unreliability results using basic event values from the 2010 Component Reliability Update^a are summarized in Section 3. Trend results for HPCS (using system-specific data) are presented in Section 4. Similar to previous system study updates, Section 5 contains importance information (using the baseline results from Section 3), and Section 7 describes the HPCS.

The HPCS model is evaluated using the large loss-of-coolant accident (LOCA) and the loss-of-offsite power (LOOP) flag sets in the SPAR model (setting the LOOP flag requires the start and run of the HPCS diesel generator). The LOOP flag set assumes all ac power is unavailable and that the HPCS system is required to perform to mitigate the effects of the LOOP initiating event. All models include failures due to unavailability while in test or maintenance. Human error and recovery events in the models are set to False in the study for the results to represent the mechanical part of the system. An overview of the trending methods, glossary of terms, and abbreviations can be found in the paper Overview and Reference [4] on the Nuclear Regulatory Commission (NRC) Reactor Operational Experience Results and Databases web page (<https://nrcoe.inl.gov/resultsdb/>).

Two modes of the models for the HPCS system are calculated. The HPCS start-only model is the HPCS SPAR model modified by setting all fail-to-run basic events to zero (False), setting all human error and recovery events to False, setting the suction transfer events to False, and setting all cooling basic events to False. The 8-hour mission model sets all human error and recovery events to False.

^a For comparison purposes, in order to keep the SPAR models and basic event data the same as those used in the previous (2016) HPCS system study, the 2010 Component Reliability Update data is used here. The only variables subject to change in this analysis were the demand, run hours, failure, and unavailability data for selected components in the HPCS system.

Table 1. BWR plants with a HPCS system selected for the study.

Plant	Version
Clinton 1	8.17
Columbia 2	8.16
Grand Gulf	8.22
La Salle 1	8.21
La Salle 2	8.21
Nine Mile Pt. 2	8.17
Perry	8.19
River Bend	8.20

2. SUMMARY OF FINDINGS

The results of this HPCS system unreliability study are summarized in this section. Of particular interest is the existence of any statistically significant^a increasing trends. In this update, **no statistically significant increasing or decreasing trends were identified** in the HPCS unreliability trend results.

The industry-wide HPCS start-only and 8-hour basic event group importances were evaluated and are shown in Figure 3:

- In the *Start-Only* case—the leading contributor to HPCS system unreliability is the **HPCS MDP** group of basic events followed by the Cooling and Diesel Generator groups.
- In the *8-Hour* case—the leading contributor to HPCS system unreliability is also the **HPCS MDP** group of basic events followed by the Cooling and Diesel Generator groups.

a Statistically significant is defined in terms of the ‘p-value.’ A p-value is a probability indicating whether to accept or reject the null hypothesis that there is no trend in the data. P-values of less than or equal to 0.05 indicate that we are 95% confident that there is a trend in the data (reject the null hypothesis of no trend.) By convention, we use the "Michelin Guide" scale: p-value < 0.05 (statistically significant), p-value < 0.01 (highly statistically significant); p-value < 0.001 (extremely statistically significant).

3. INDUSTRY-WIDE UNRELIABILITY

The HPCS fault trees from the SPAR models were evaluated for each of the eight operating U.S. commercial boiling water nuclear power plants with an HPCS system.

The industry-wide unreliability of the HPCS system has been estimated for two modes of operation. A start-only model and an 8-hour mission model were evaluated. The uncertainty distributions for HPCS show both plant design variability and parameter uncertainty while using industry-wide component failure data (1998–2010).^a Table 2 shows the percentiles and mean of the aggregated sample data (Latin hypercube, 1000 samples for each model) collected from the uncertainty calculations of the HPCS fault trees in the SPAR models.

Table 2. Industry-wide unreliability values.

Model	Lower (5%)	Median	Mean	Upper (95%)
Start	8.63E-03	2.69E-02	3.09E-02	6.69E-02
8-hour	8.79E-03	3.16E-02	3.57E-02	7.72E-02

a. By using industry-wide component failure data, individual plant performance is not included in the distribution of results.

4. INDUSTRY-WIDE TRENDS

The yearly (1998 through 2018) failure and demand or run time data were obtained from ICES for the HPCS system. HPCS train maintenance unavailability data for trending are from the same time period, as reported in the ROP program and ICES. The component basic event uncertainty was calculated for the HPCS system components using the trending methods described in Section 1 and 2 of the Overview and Reference document [4]. Tables 6 and 7 show the yearly data values for each HPCS system specific component and failure mode combination that was varied in the model. These data were loaded into the HPCS system fault tree in each SPAR model with a HPCS system (see Table 1).

The trend charts show the results of varying component reliability data over time and updating generic, relatively-flat prior distributions (or constrained noninformative distributions, refer to Section 2 of the Overview and Reference document) using data for each year. In addition, for comparison, the calculated industry-wide system reliability from this update (current SPAR/ICES) is shown. Section 4 of the Overview and Reference document provides more detailed discussion of the trending methods. In the lower left hand corner of the trend figures, the regression method is reported.

The components that were varied in the HPCS model are:

- HPCS diesel generator start, run, and test and maintenance.
- HPCS motor-driven pump (MDP) start, run, and test and maintenance.
- HPCS motor-operated valve (MOV) fail to operate.

Figure 1 shows the trend in the start-only model unreliability. Table 4 shows the data points for Figure 1. **No statistically significant trend was identified** within the industry-wide estimates of HPCS system unreliability (start-only) on a per fiscal year basis.

Figure 2 shows the trend in the 8-hour mission unreliability. Table 5 shows the data points for Figure 2. **No statistically significant trend was identified** within the industry-wide estimates of HPCS system unreliability (8-hour mission) on a per fiscal year basis.

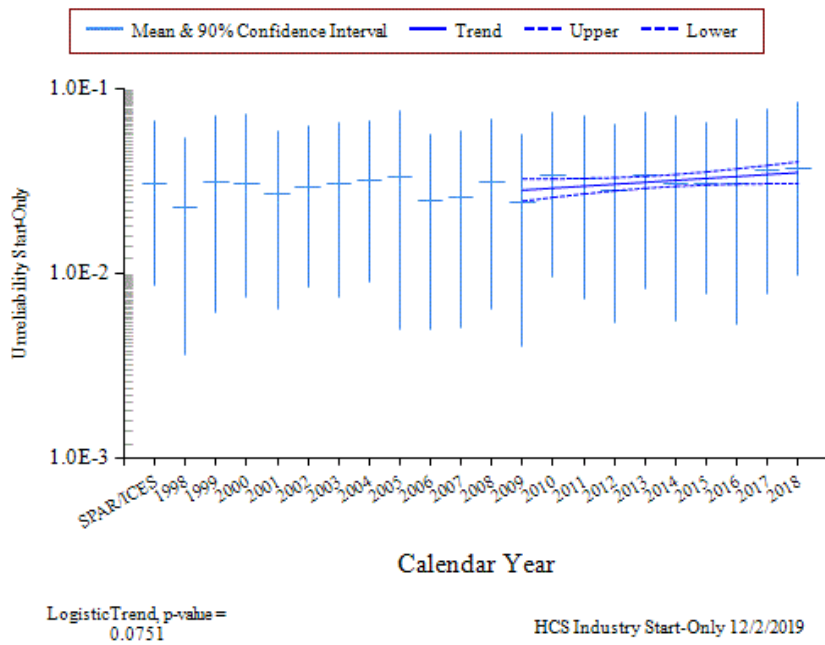

Figure 1. Trend of HPCS system unreliability (start-only model), as a function of fiscal year.

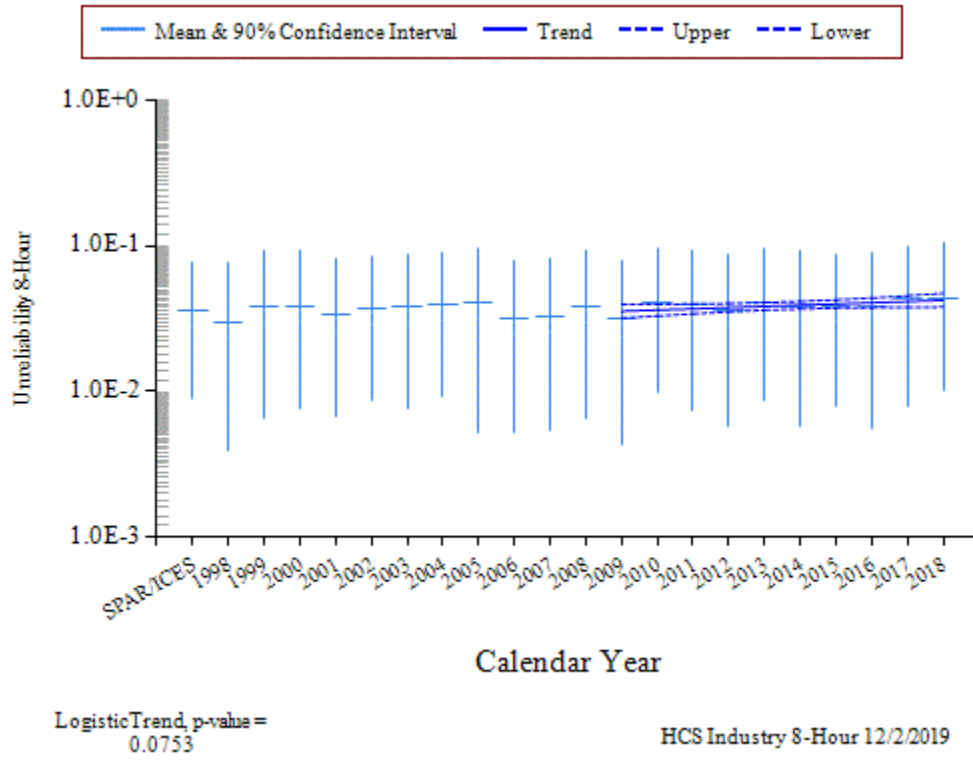

Figure 2. Trend of HPCS system unreliability (8-hour model), as a function of fiscal year.

5. BASIC EVENT GROUP IMPORTANCES

The HPCS basic event group Fussell-Vesely importances were calculated for the start-only and 8-hour models for each plant using the industry-wide data (1998–2010). These basic event group importances were then averaged across all plants to represent an industry-wide basic event group importance.

The industry-wide HPCS start-only and 8-hour basic event group importances are shown in Figure 3:

- In the *Start-Only* case—the leading contributor to HPCS system unreliability is the **HPCS MDP** group of basic events followed by the Cooling and Diesel Generator groups.
- In the *8-Hour* case—the leading contributor to HPCS system unreliability is also the **HPCS MDP** group of basic events followed by the Cooling and Diesel Generator groups.

For more discussion on the HPCS motor-driven pumps and diesel generators, see the motor-driven pump and diesel generator component reliability studies at the NRC Reactor Operational Experience Results and Databases web page (<https://nrcoe.inl.gov/resultsdb/>). Table 3 shows the SPAR model HPCS importance groups and their descriptions.

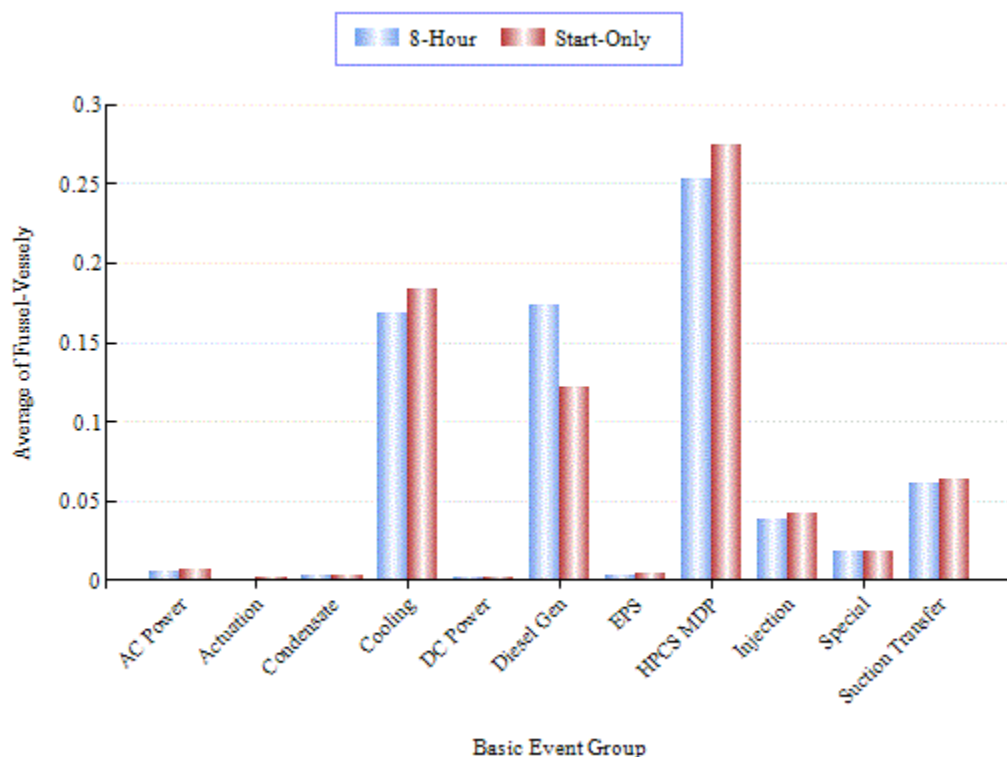

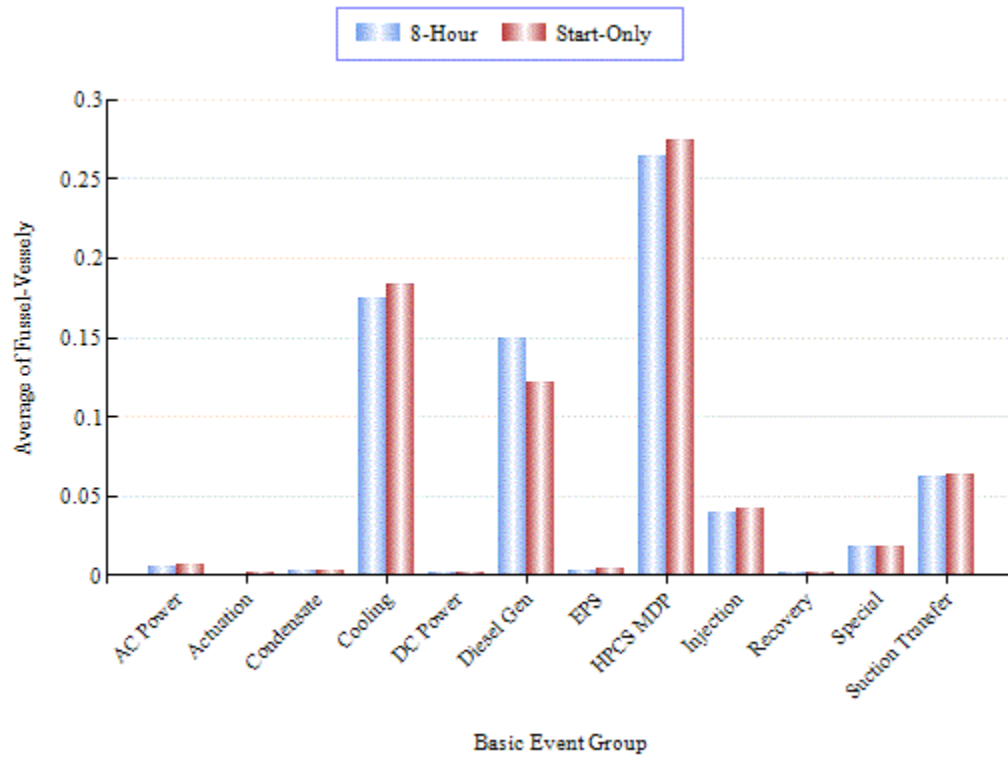

Figure 3. HPCS basic event group importances.

Table 3. HPCS model basic event importance group descriptions.

Group	Description
AC Power	The ac buses and circuit breakers that supply power to the HPCS pump and other loads.
Actuation	ESF actuation circuitry.
Condensate	The motor-operated valves and air-operated valves in the condensate storage tank suction path. Includes the failure of the condensate storage tank.
Cooling	The pumps, valves, and heat exchangers that provide heat removal to the HPCS motor-driven pump and the HPCS room.
DC Power	The batteries and battery chargers that supply power to the HPCS motor -driven pump control circuitry.
Diesel Generator	All basic events associated with the primary emergency power supplies. Includes diesel, gas turbine, and hydro powered equipment. The start, run, common-cause, and test and maintenance are included in the group of basic events.
HPCS MDP	All basic events associated with the motor-driven pumps. The start, run, common-cause, and test and maintenance are included in the group of basic events.
Injection	The motor-operated valves and check valves in the HPCS injection path.
Special	Various events used in the models that are not directly associated with the HPCS system.
Suction Transfer	The suppression pool motor-operated valves, check valves, and strainers required when a need to transfer to the suppression pool (torus) occurs.

6. DATA TABLES

Table 4. Plot data for HPCI start-only trend, Figure 1.

Year/Source	Regression Curve Data Points			Annual Estimate Data Points		
	Lower (5%)	Mean	Upper (95%)	Lower (5%)	Mean	Upper (95%)
SPAR/ICES	--	--	--	8.63E-03	3.09E-02	6.69E-02
1998	--	--	--	3.64E-03	2.27E-02	5.45E-02
1999	--	--	--	6.17E-03	3.15E-02	7.12E-02
2000	--	--	--	7.41E-03	3.07E-02	7.20E-02
2001	--	--	--	6.39E-03	2.67E-02	5.93E-02
2002	--	--	--	8.52E-03	2.95E-02	6.23E-02
2003	--	--	--	7.45E-03	3.05E-02	6.49E-02
2004	--	--	--	9.05E-03	3.22E-02	6.73E-02
2005	--	--	--	4.97E-03	3.30E-02	7.64E-02
2006	--	--	--	5.00E-03	2.45E-02	5.64E-02
2007	--	--	--	5.13E-03	2.58E-02	5.92E-02
2008	--	--	--	6.40E-03	3.10E-02	6.82E-02
2009	2.47E-02	2.83E-02	3.24E-02	4.06E-03	2.42E-02	5.63E-02
2010	2.58E-02	2.90E-02	3.25E-02	9.59E-03	3.42E-02	7.36E-02
2011	2.70E-02	2.97E-02	3.27E-02	7.23E-03	3.24E-02	7.05E-02
2012	2.80E-02	3.04E-02	3.30E-02	5.46E-03	2.84E-02	6.44E-02
2013	2.90E-02	3.12E-02	3.36E-02	8.29E-03	3.39E-02	7.33E-02
2014	2.97E-02	3.19E-02	3.44E-02	5.49E-03	3.07E-02	7.05E-02
2015	3.01E-02	3.27E-02	3.55E-02	7.76E-03	3.05E-02	6.56E-02
2016	3.04E-02	3.35E-02	3.69E-02	5.35E-03	3.04E-02	6.81E-02
2017	3.06E-02	3.43E-02	3.85E-02	7.72E-03	3.62E-02	7.79E-02
2018	3.07E-02	3.52E-02	4.02E-02	9.80E-03	3.67E-02	8.45E-02

Table 5. Plot data for HPCS 8-hour trend, Figure 2.

Year/Source	Regression Curve Data Points			Annual Estimate Data Points		
	Lower (5%)	Mean	Upper (95%)	Lower (5%)	Mean	Upper (95%)
SPAR/ICES	--	--	--	8.79E-03	3.57E-02	7.72E-02
1998	--	--	--	3.90E-03	3.00E-02	7.69E-02
1999	--	--	--	6.41E-03	3.86E-02	9.38E-02
2000	--	--	--	7.63E-03	3.79E-02	9.37E-02
2001	--	--	--	6.61E-03	3.40E-02	8.22E-02
2002	--	--	--	8.67E-03	3.67E-02	8.47E-02
2003	--	--	--	7.60E-03	3.77E-02	8.83E-02
2004	--	--	--	9.22E-03	3.94E-02	9.08E-02
2005	--	--	--	5.23E-03	4.02E-02	9.60E-02
2006	--	--	--	5.25E-03	3.18E-02	7.98E-02
2007	--	--	--	5.37E-03	3.31E-02	8.25E-02
2008	--	--	--	6.60E-03	3.82E-02	9.14E-02
2009	3.19E-02	3.56E-02	3.96E-02	4.31E-03	3.14E-02	8.01E-02
2010	3.31E-02	3.62E-02	3.97E-02	9.77E-03	4.13E-02	9.60E-02
2011	3.42E-02	3.70E-02	3.99E-02	7.37E-03	3.95E-02	9.30E-02
2012	3.53E-02	3.77E-02	4.02E-02	5.71E-03	3.56E-02	8.77E-02
2013	3.62E-02	3.84E-02	4.07E-02	8.52E-03	4.11E-02	9.51E-02
2014	3.69E-02	3.92E-02	4.15E-02	5.75E-03	3.78E-02	9.22E-02
2015	3.74E-02	3.99E-02	4.26E-02	7.95E-03	3.77E-02	8.78E-02
2016	3.77E-02	4.07E-02	4.39E-02	5.60E-03	3.76E-02	9.07E-02
2017	3.79E-02	4.15E-02	4.54E-02	7.88E-03	4.34E-02	9.89E-02
2018	3.80E-02	4.23E-02	4.71E-02	9.97E-03	4.39E-02	1.06E-01

Table 6. Basic event reliability trending data.

Failure Mode	Component	Year	Number of Failures	Demands/Run Hours	Bayesian Update			Distribution
					Mean	Post A	Post B	
FTLR	GEN	1998	0	106	3.30E-03	2.77	8.37E+02	Beta
FTLR	GEN	1999	1	131	4.37E-03	3.77	8.61E+02	Beta
FTLR	GEN	2000	0	121	3.25E-03	2.77	8.52E+02	Beta
FTLR	GEN	2001	0	125	3.23E-03	2.77	8.56E+02	Beta
FTLR	GEN	2002	1	124	4.40E-03	3.77	8.54E+02	Beta
FTLR	GEN	2003	0	129	3.22E-03	2.77	8.60E+02	Beta
FTLR	GEN	2004	1	129	4.37E-03	3.77	8.59E+02	Beta
FTLR	GEN	2005	0	119	3.25E-03	2.77	8.50E+02	Beta
FTLR	GEN	2006	0	124	3.23E-03	2.77	8.55E+02	Beta
FTLR	GEN	2007	0	117	3.26E-03	2.77	8.48E+02	Beta
FTLR	GEN	2008	0	139	3.18E-03	2.77	8.70E+02	Beta
FTLR	GEN	2009	0	118	3.26E-03	2.77	8.49E+02	Beta
FTLR	GEN	2010	1	132	4.36E-03	3.77	8.62E+02	Beta
FTLR	GEN	2011	0	137	3.19E-03	2.77	8.68E+02	Beta
FTLR	GEN	2012	1	117	4.44E-03	3.77	8.47E+02	Beta
FTLR	GEN	2013	0	137	3.19E-03	2.77	8.68E+02	Beta
FTLR	GEN	2014	1	118	4.43E-03	3.77	8.48E+02	Beta
FTLR	GEN	2015	1	127	4.38E-03	3.77	8.57E+02	Beta
FTLR	GEN	2016	0	126	3.23E-03	2.77	8.57E+02	Beta
FTLR	GEN	2017	0	125	3.23E-03	2.77	8.56E+02	Beta
FTLR	GEN	2018	1	129	4.37E-03	3.77	8.59E+02	Beta
FTR	GEN	1998	0	296	9.97E-04	3.55	3.56E+03	Gamma
FTR	GEN	1999	1	459	1.22E-03	4.55	3.73E+03	Gamma
FTR	GEN	2000	0	348	9.83E-04	3.55	3.62E+03	Gamma
FTR	GEN	2001	0	361	9.79E-04	3.55	3.63E+03	Gamma
FTR	GEN	2002	0	327	9.88E-04	3.55	3.59E+03	Gamma
FTR	GEN	2003	0	391	9.71E-04	3.55	3.66E+03	Gamma
FTR	GEN	2004	0	331	9.87E-04	3.55	3.60E+03	Gamma
FTR	GEN	2005	1	376	1.25E-03	4.55	3.64E+03	Gamma
FTR	GEN	2006	0	379	9.75E-04	3.55	3.65E+03	Gamma
FTR	GEN	2007	0	307	9.94E-04	3.55	3.57E+03	Gamma
FTR	GEN	2008	0	452	9.55E-04	3.55	3.72E+03	Gamma
FTR	GEN	2009	0	381	9.74E-04	3.55	3.65E+03	Gamma
FTR	GEN	2010	1	392	1.24E-03	4.55	3.66E+03	Gamma
FTR	GEN	2011	0	425	9.62E-04	3.55	3.69E+03	Gamma
FTR	GEN	2012	0	162	1.04E-03	3.55	3.43E+03	Gamma
FTR	GEN	2013	1	298	1.28E-03	4.55	3.57E+03	Gamma
FTR	GEN	2014	0	194	1.03E-03	3.55	3.46E+03	Gamma
FTR	GEN	2015	0	228	1.02E-03	3.55	3.50E+03	Gamma
FTR	GEN	2016	1	205	1.31E-03	4.55	3.47E+03	Gamma
FTR	GEN	2017	0	195	1.03E-03	3.55	3.46E+03	Gamma

Table 6. (continued).

Failure Mode	Component	Year	Number of Failures	Demands/Run Hours	Bayesian Update			Distribution
					Mean	Post A	Post B	
FTR	GEN	2018	2	186	1.61E-03	5.55	3.45E+03	Gamma
FTS	GEN	1998	0	151	2.74E-03	8.11	2.95E+03	Beta
FTS	GEN	1999	1	187	3.04E-03	9.11	2.98E+03	Beta
FTS	GEN	2000	0	145	2.75E-03	8.11	2.94E+03	Beta
FTS	GEN	2001	0	154	2.74E-03	8.11	2.95E+03	Beta
FTS	GEN	2002	0	140	2.75E-03	8.11	2.94E+03	Beta
FTS	GEN	2003	0	152	2.74E-03	8.11	2.95E+03	Beta
FTS	GEN	2004	0	139	2.75E-03	8.11	2.94E+03	Beta
FTS	GEN	2005	0	133	2.76E-03	8.11	2.93E+03	Beta
FTS	GEN	2006	0	136	2.76E-03	8.11	2.93E+03	Beta
FTS	GEN	2007	0	126	2.77E-03	8.11	2.92E+03	Beta
FTS	GEN	2008	1	152	3.08E-03	9.11	2.95E+03	Beta
FTS	GEN	2009	0	138	2.75E-03	8.11	2.94E+03	Beta
FTS	GEN	2010	0	151	2.74E-03	8.11	2.95E+03	Beta
FTS	GEN	2011	0	152	2.74E-03	8.11	2.95E+03	Beta
FTS	GEN	2012	0	128	2.76E-03	8.11	2.93E+03	Beta
FTS	GEN	2013	0	158	2.74E-03	8.11	2.96E+03	Beta
FTS	GEN	2014	1	136	3.10E-03	9.11	2.93E+03	Beta
FTS	GEN	2015	0	140	2.75E-03	8.11	2.94E+03	Beta
FTS	GEN	2016	0	138	2.76E-03	8.11	2.94E+03	Beta
FTS	GEN	2017	0	139	2.75E-03	8.11	2.94E+03	Beta
FTS	GEN	2018	1	144	3.09E-03	9.11	2.94E+03	Beta
FTR>1H	MDP	1998	0	779	1.03E-05	0.78	7.58E+04	Gamma
FTR>1H	MDP	1999	0	116	1.04E-05	0.78	7.51E+04	Gamma
FTR>1H	MDP	2000	0	67	1.04E-05	0.78	7.51E+04	Gamma
FTR>1H	MDP	2001	0	59	1.04E-05	0.78	7.51E+04	Gamma
FTR>1H	MDP	2002	0	56	1.04E-05	0.78	7.51E+04	Gamma
FTR>1H	MDP	2003	0	93	1.04E-05	0.78	7.51E+04	Gamma
FTR>1H	MDP	2004	0	64	1.04E-05	0.78	7.51E+04	Gamma
FTR>1H	MDP	2005	0	143	1.04E-05	0.78	7.52E+04	Gamma
FTR>1H	MDP	2006	0	90	1.04E-05	0.78	7.51E+04	Gamma
FTR>1H	MDP	2007	0	89	1.04E-05	0.78	7.51E+04	Gamma
FTR>1H	MDP	2008	0	97	1.04E-05	0.78	7.51E+04	Gamma
FTR>1H	MDP	2009	0	108	1.04E-05	0.78	7.51E+04	Gamma
FTR>1H	MDP	2010	0	99	1.04E-05	0.78	7.51E+04	Gamma
FTR>1H	MDP	2011	0	134	1.04E-05	0.78	7.51E+04	Gamma
FTR>1H	MDP	2012	0	96	1.04E-05	0.78	7.51E+04	Gamma
FTR>1H	MDP	2013	0	144	1.04E-05	0.78	7.52E+04	Gamma
FTR>1H	MDP	2014	0	92	1.04E-05	0.78	7.51E+04	Gamma
FTR>1H	MDP	2015	0	104	1.04E-05	0.78	7.51E+04	Gamma
FTR>1H	MDP	2016	0	111	1.04E-05	0.78	7.51E+04	Gamma

Table 6. (continued).

Failure Mode	Component	Year	Number of Failures	Demands/Run Hours	Bayesian Update			Distribution
					Mean	Post A	Post B	
FTR>1H	MDP	2017	0	97	1.04E-05	0.78	7.51E+04	Gamma
FTR>1H	MDP	2018	0	97	1.04E-05	0.78	7.51E+04	Gamma
FTR<1H	MDP	1998	0	83	1.22E-04	1.82	1.49E+04	Gamma
FTR<1H	MDP	1999	0	116	1.22E-04	1.82	1.49E+04	Gamma
FTR<1H	MDP	2000	0	88	1.22E-04	1.82	1.49E+04	Gamma
FTR<1H	MDP	2001	0	82	1.22E-04	1.82	1.49E+04	Gamma
FTR<1H	MDP	2002	0	136	1.22E-04	1.82	1.49E+04	Gamma
FTR<1H	MDP	2003	0	175	1.22E-04	1.82	1.50E+04	Gamma
FTR<1H	MDP	2004	0	141	1.22E-04	1.82	1.49E+04	Gamma
FTR<1H	MDP	2005	0	138	1.22E-04	1.82	1.49E+04	Gamma
FTR<1H	MDP	2006	0	121	1.22E-04	1.82	1.49E+04	Gamma
FTR<1H	MDP	2007	0	102	1.22E-04	1.82	1.49E+04	Gamma
FTR<1H	MDP	2008	0	120	1.22E-04	1.82	1.49E+04	Gamma
FTR<1H	MDP	2009	0	85	1.22E-04	1.82	1.49E+04	Gamma
FTR<1H	MDP	2010	0	101	1.22E-04	1.82	1.49E+04	Gamma
FTR<1H	MDP	2011	0	94	1.22E-04	1.82	1.49E+04	Gamma
FTR<1H	MDP	2012	0	86	1.22E-04	1.82	1.49E+04	Gamma
FTR<1H	MDP	2013	0	113	1.22E-04	1.82	1.49E+04	Gamma
FTR<1H	MDP	2014	0	95	1.22E-04	1.82	1.49E+04	Gamma
FTR<1H	MDP	2015	0	102	1.22E-04	1.82	1.49E+04	Gamma
FTR<1H	MDP	2016	0	89	1.22E-04	1.82	1.49E+04	Gamma
FTR<1H	MDP	2017	0	94	1.22E-04	1.82	1.49E+04	Gamma
FTR<1H	MDP	2018	0	108	1.22E-04	1.82	1.49E+04	Gamma
FTS	MDP	1998	0	83	9.11E-04	1.95	2.14E+03	Beta
FTS	MDP	1999	0	116	8.97E-04	1.95	2.17E+03	Beta
FTS	MDP	2000	0	88	9.09E-04	1.95	2.14E+03	Beta
FTS	MDP	2001	0	82	9.11E-04	1.95	2.14E+03	Beta
FTS	MDP	2002	1	136	1.35E-03	2.95	2.19E+03	Beta
FTS	MDP	2003	0	175	8.73E-04	1.95	2.23E+03	Beta
FTS	MDP	2004	0	141	8.87E-04	1.95	2.19E+03	Beta
FTS	MDP	2005	1	138	1.34E-03	2.95	2.19E+03	Beta
FTS	MDP	2006	0	121	8.95E-04	1.95	2.18E+03	Beta
FTS	MDP	2007	0	102	9.03E-04	1.95	2.16E+03	Beta
FTS	MDP	2008	0	120	8.95E-04	1.95	2.17E+03	Beta
FTS	MDP	2009	0	85	9.10E-04	1.95	2.14E+03	Beta
FTS	MDP	2010	1	101	1.37E-03	2.95	2.15E+03	Beta
FTS	MDP	2011	0	94	9.06E-04	1.95	2.15E+03	Beta
FTS	MDP	2012	0	86	9.09E-04	1.95	2.14E+03	Beta
FTS	MDP	2013	0	113	8.98E-04	1.95	2.17E+03	Beta
FTS	MDP	2014	0	95	9.06E-04	1.95	2.15E+03	Beta
FTS	MDP	2015	0	102	9.03E-04	1.95	2.16E+03	Beta

Table 6. (continued).

Failure Mode	Component	Year	Number of Failures	Demands/Run Hours	Bayesian Update			Distribution
					Mean	Post A	Post B	
FTS	MDP	2016	0	89	9.08E-04	1.95	2.14E+03	Beta
FTS	MDP	2017	0	94	9.06E-04	1.95	2.15E+03	Beta
FTS	MDP	2018	1	108	1.36E-03	2.95	2.16E+03	Beta
FTOC	MOV	1998	0	208	8.77E-04	2.05	2.33E+03	Beta
FTOC	MOV	1999	0	299	8.44E-04	2.05	2.42E+03	Beta
FTOC	MOV	2000	0	221	8.72E-04	2.05	2.34E+03	Beta
FTOC	MOV	2001	0	226	8.70E-04	2.05	2.35E+03	Beta
FTOC	MOV	2002	0	299	8.44E-04	2.05	2.42E+03	Beta
FTOC	MOV	2003	0	320	8.37E-04	2.05	2.44E+03	Beta
FTOC	MOV	2004	0	266	8.56E-04	2.05	2.39E+03	Beta
FTOC	MOV	2005	0	254	8.60E-04	2.05	2.38E+03	Beta
FTOC	MOV	2006	0	266	8.56E-04	2.05	2.39E+03	Beta
FTOC	MOV	2007	0	256	8.59E-04	2.05	2.38E+03	Beta
FTOC	MOV	2008	0	236	8.67E-04	2.05	2.36E+03	Beta
FTOC	MOV	2009	0	214	8.75E-04	2.05	2.34E+03	Beta
FTOC	MOV	2010	0	229	8.69E-04	2.05	2.35E+03	Beta
FTOC	MOV	2011	0	229	8.69E-04	2.05	2.35E+03	Beta
FTOC	MOV	2012	0	239	8.66E-04	2.05	2.36E+03	Beta
FTOC	MOV	2013	0	216	8.74E-04	2.05	2.34E+03	Beta
FTOC	MOV	2014	0	228	8.70E-04	2.05	2.35E+03	Beta
FTOC	MOV	2015	0	214	8.75E-04	2.05	2.34E+03	Beta
FTOC	MOV	2016	0	217	8.74E-04	2.05	2.34E+03	Beta
FTOC	MOV	2017	1	207	1.31E-03	3.05	2.33E+03	Beta
FTOC	MOV	2018	0	217	8.74E-04	2.05	2.34E+03	Beta
FTOP	MOV	1998	0	262,800	6.53E-08	1.46	2.23E+07	Gamma
FTOP	MOV	1999	1	262,800	1.10E-07	2.46	2.23E+07	Gamma
FTOP	MOV	2000	0	262,800	6.53E-08	1.46	2.23E+07	Gamma
FTOP	MOV	2001	0	262,800	6.53E-08	1.46	2.23E+07	Gamma
FTOP	MOV	2002	0	262,800	6.53E-08	1.46	2.23E+07	Gamma
FTOP	MOV	2003	0	262,800	6.53E-08	1.46	2.23E+07	Gamma
FTOP	MOV	2004	0	262,800	6.53E-08	1.46	2.23E+07	Gamma
FTOP	MOV	2005	0	262,800	6.53E-08	1.46	2.23E+07	Gamma
FTOP	MOV	2006	0	262,800	6.53E-08	1.46	2.23E+07	Gamma
FTOP	MOV	2007	0	262,800	6.53E-08	1.46	2.23E+07	Gamma
FTOP	MOV	2008	0	262,800	6.53E-08	1.46	2.23E+07	Gamma
FTOP	MOV	2009	0	262,800	6.53E-08	1.46	2.23E+07	Gamma
FTOP	MOV	2010	0	262,800	6.53E-08	1.46	2.23E+07	Gamma
FTOP	MOV	2011	0	271,560	6.53E-08	1.46	2.23E+07	Gamma
FTOP	MOV	2012	0	262,800	6.53E-08	1.46	2.23E+07	Gamma
FTOP	MOV	2013	0	262,800	6.53E-08	1.46	2.23E+07	Gamma
FTOP	MOV	2014	0	262,800	6.53E-08	1.46	2.23E+07	Gamma

Table 6. (continued).

Failure Mode	Component	Year	Number of Failures	Demands/Run Hours	Bayesian Update			Distribution
					Mean	Post A	Post B	
FTOP	MOV	2015	0	262,800	6.53E-08	1.46	2.23E+07	Gamma
FTOP	MOV	2016	0	262,800	6.53E-08	1.46	2.23E+07	Gamma
FTOP	MOV	2017	0	262,800	6.53E-08	1.46	2.23E+07	Gamma
FTOP	MOV	2018	0	262,800	6.53E-08	1.46	2.23E+07	Gamma
SO	MOV	1998	0	262,800	3.33E-08	0.57	1.71E+07	Gamma
SO	MOV	1999	0	262,800	3.33E-08	0.57	1.71E+07	Gamma
SO	MOV	2000	0	262,800	3.33E-08	0.57	1.71E+07	Gamma
SO	MOV	2001	0	262,800	3.33E-08	0.57	1.71E+07	Gamma
SO	MOV	2002	0	262,800	3.33E-08	0.57	1.71E+07	Gamma
SO	MOV	2003	0	262,800	3.33E-08	0.57	1.71E+07	Gamma
SO	MOV	2004	0	262,800	3.33E-08	0.57	1.71E+07	Gamma
SO	MOV	2005	0	262,800	3.33E-08	0.57	1.71E+07	Gamma
SO	MOV	2006	0	262,800	3.33E-08	0.57	1.71E+07	Gamma
SO	MOV	2007	0	262,800	3.33E-08	0.57	1.71E+07	Gamma
SO	MOV	2008	0	262,800	3.33E-08	0.57	1.71E+07	Gamma
SO	MOV	2009	0	262,800	3.33E-08	0.57	1.71E+07	Gamma
SO	MOV	2010	0	262,800	3.33E-08	0.57	1.71E+07	Gamma
SO	MOV	2011	0	271,560	3.33E-08	0.57	1.71E+07	Gamma
SO	MOV	2012	0	262,800	3.33E-08	0.57	1.71E+07	Gamma
SO	MOV	2013	0	262,800	3.33E-08	0.57	1.71E+07	Gamma
SO	MOV	2014	0	262,800	3.33E-08	0.57	1.71E+07	Gamma
SO	MOV	2015	0	262,800	3.33E-08	0.57	1.71E+07	Gamma
SO	MOV	2016	0	262,800	3.33E-08	0.57	1.71E+07	Gamma
SO	MOV	2017	0	262,800	3.33E-08	0.57	1.71E+07	Gamma
SO	MOV	2018	0	262,800	3.33E-08	0.57	1.71E+07	Gamma

Table 7. Basic event UA trending data.

Failure Mode	Component	Year	UA Hours	Critical Hours	Bayesian Update			
					Mean	Post A	Post B	Distribution
UA	EDG	1998	254.5	42,029	4.27E-03	1.36	3.17E+02	Beta
UA	EDG	1999	760.23	55,565	1.35E-02	1.01	7.38E+01	Beta
UA	EDG	2000	958.9	65,705	1.48E-02	1.04	6.92E+01	Beta
UA	EDG	2001	473.52	65,093	7.13E-03	2	2.78E+02	Beta
UA	EDG	2002	430.77	65,329	6.66E-03	1.94	2.89E+02	Beta
UA	EDG	2003	825.09	65,040	1.26E-02	7.32	5.73E+02	Beta
UA	EDG	2004	854.78	65,589	1.31E-02	3.42	2.58E+02	Beta
UA	EDG	2005	610.37	64,383	9.42E-03	4.7	4.94E+02	Beta
UA	EDG	2006	452.56	66,949	6.71E-03	3.03	4.48E+02	Beta
UA	EDG	2007	591.53	64,512	9.14E-03	2.29	2.48E+02	Beta
UA	EDG	2008	860.99	65,262	1.36E-02	1.92	1.40E+02	Beta
UA	EDG	2009	519.11	63,966	8.13E-03	3.52	4.29E+02	Beta
UA	EDG	2010	1049.56	67,158	1.55E-02	1.76	1.12E+02	Beta
UA	EDG	2011	990.72	62,329	1.58E-02	3.02	1.88E+02	Beta
UA	EDG	2012	815.28	64,557	1.24E-02	1.99	1.59E+02	Beta
UA	EDG	2013	952.33	64,142	1.45E-02	1.84	1.25E+02	Beta
UA	EDG	2014	1011.86	66,677	1.51E-02	1.82	1.19E+02	Beta
UA	EDG	2015	627.2	65,277	9.56E-03	1.72	1.78E+02	Beta
UA	EDG	2016	884.35	62,704	1.37E-02	2.45	1.77E+02	Beta
UA	EDG	2017	827.43	63,353	1.36E-02	1.59	1.15E+02	Beta
UA	EDG	2018	1345.77	64,262	2.12E-02	1.12	5.18E+01	Beta
UA	MDP	1998	194.5	42,029	2.98E-03	0.56	1.89E+02	Beta
UA	MDP	1999	422.21	55,565	8.11E-03	1.28	1.56E+02	Beta
UA	MDP	2000	433.44	65,705	6.68E-03	3.83	5.69E+02	Beta
UA	MDP	2001	388.14	65,093	5.88E-03	2.44	4.12E+02	Beta
UA	MDP	2002	554.31	65,329	8.47E-03	3.06	3.58E+02	Beta
UA	MDP	2003	476.66	65,040	7.53E-03	2.86	3.77E+02	Beta
UA	MDP	2004	594.42	65,589	9.01E-03	4.44	4.88E+02	Beta
UA	MDP	2005	672.14	64,383	1.08E-02	0.47	4.26E+01	Beta
UA	MDP	2006	262.42	66,949	3.88E-03	1.89	4.87E+02	Beta
UA	MDP	2007	267.37	64,512	4.13E-03	1.89	4.55E+02	Beta
UA	MDP	2008	495.37	65,262	7.53E-03	1.55	2.04E+02	Beta
UA	MDP	2009	167.43	63,966	2.83E-03	1.02	3.58E+02	Beta
UA	MDP	2010	636.15	67,158	9.46E-03	3.94	4.12E+02	Beta
UA	MDP	2011	497.12	62,329	7.99E-03	2.1	2.61E+02	Beta
UA	MDP	2012	359.63	64,557	5.35E-03	1.5	2.78E+02	Beta
UA	MDP	2013	661.49	64,142	1.01E-02	2.21	2.16E+02	Beta
UA	MDP	2014	441.5	66,677	6.54E-03	1.16	1.76E+02	Beta
UA	MDP	2015	579.38	65,277	8.72E-03	2.34	2.66E+02	Beta
UA	MDP	2016	468.57	62,704	6.90E-03	1	1.43E+02	Beta
UA	MDP	2017	724.01	63,353	1.20E-02	1.11	9.15E+01	Beta
UA	MDP	2018	623	64,262	9.62E-03	4.19	4.32E+02	Beta

Table 8. Failure mode acronyms.

Failure Mode	Failure Mode Description
FTLR	Fail to load/run
FTOC	Fail to open/close
FTOP	Fail to operate
FTR	Fail to run
FTR>1H	Fail to run greater than one hour
FTR<1H	Fail to run less than one hour (after start)
FTS	Fail to start
SO	Spurious operation
UA	Unavailability (maintenance or state of another component)

7. SYSTEM DESCRIPTION

This study documents an analysis of the operational experience of the eight BWRs listed in Table 9, all of which have an HPCS system. The analysis focused on the ability of the HPCS system to start and provide its associated emergency core cooling function for the required mission. The HPCS model is evaluated using the LLOCA and the LOOP flag sets in the SPAR model (setting the LOOP flag requires the start and run of the HPCS diesel generator). The LOOP flag set assumes all ac power is unavailable and that the HPCS system is required to perform to mitigate the effects of the LOOP initiating event. The system boundaries, data collection, failure categorization, and limitations of the study are briefly described in this section. Table 9 presents each plant's docket number and the configuration of the cooling water system for HPCS.

The emergency core cooling system in the BWRs studied typically consists of the automatic depressurization system (ADS), the HPCS system, the low-pressure core spray (LPCS) system, and the low-pressure coolant injection (LPCI) mode of the residual heat removal system. The purpose of these systems is to reestablish adequate core cooling and maintain continuity of core cooling subsequent to the entire spectrum of postulated loss-of-coolant accidents (LOCAs).

If a LOCA should occur, a low reactor water level signal or high drywell pressure signal initiates the HPCS system and its support equipment. The system can also be placed in operation manually. If the leak rate is less than the HPCS system flow rate, the HPCS system automatically stops when a high reactor water level signal shuts the HPCS injection valve. The injection valve will automatically reopen upon a subsequent low water level signal. Should the leak rate exceed the HPCS system capacity and not result in rapid depressurization of the vessel, the ADS will actuate on a lower water level signal and depressurize the vessel for the LPCS and LPCI systems to provide adequate core cooling. Should the HPCS system fail to initiate during a LOCA, the ADS vessel depressurization and subsequent LPCS and LPCI system initiations will provide adequate core cooling as a backup for the HPCS system.

The HPCS system also serves as a backup to the reactor core isolation cooling (RCIC) system in the event the reactor becomes isolated from the main condenser during operation and feedwater flow is lost. Operational transients that may require HPCS are transients that include a reactor trip and a demand for coolant injection by high-pressure makeup systems (RCIC or HPCS). For example, a transient that results in a reactor trip without a loss of feedwater may require short-term operation of the HPCS and/or other high-pressure makeup system to restore reactor pressure vessel (RPV) water level. For a transient that includes a reactor trip and a loss of feedwater, with no immediate recovery of feedwater, high-pressure makeup is required to restore and maintain RPV water level. The latter type of transient would require longer operation of high-pressure makeup compared to the transients that do not lose feedwater.

Table 9. BWR plants with an HPCS system.

Plant	Docket	Dedicated Service Water System
Clinton 1	461	Yes
Grand Gulf	416	Yes
La Salle 1	343	Yes
La Salle 2	374	Yes
Nine Mile Pt. 2	410	No
Perry	440	Yes
River Bend	458	No
Columbia 2	397	Yes

The primary function of the HPCS system is to maintain reactor vessel inventory for line breaks up to 1-in. nominal size. The HPCS system also provides spray cooling heat transfer during breaks in which uncovering of the core is assumed. The HPCS system pumps water through a peripheral ring spray sparger mounted above the reactor core and can supply coolant over the entire range of system operation pressures.

The HPCS system consists of a single motor-driven centrifugal pump located outside primary containment, an independent spray sparger in the reactor vessel located above the core, and associated piping, valves, controls, and instrumentation. Figure 4 is a simplified schematic of the system. The system is designed to operate using normal offsite auxiliary power. Should a loss of offsite power occur, a dedicated backup source of power is available from a diesel generator. The backup source of power (diesel generator) only affects the unreliability of the HPCS system when a loss of offsite power occurs as an initiator or during an HPCS system demand.

The principal active HPCS equipment is located outside the primary containment. Suction piping for the HPCS pump is provided from the condensate storage tank and the suppression pool. Such an arrangement provides the capability to use reactor-grade water from the condensate storage tank when the HPCS system functions to back up the RCIC system. In the event that the condensate storage tank water supply becomes exhausted or is not available, automatic switchover to the suppression pool water source ensures a cooling water supply for long-term operation of the system.

The HPCS system consists of a motor-driven centrifugal pump located outside the primary containment, a spray header located in the RPV, and associated piping, valves, controls, and instrumentation. The HPCS system also includes a dedicated backup power source consisting of a diesel generator and its support systems, including lubricating oil, fuel oil and transfer, air start, control, and engine cooling water. In addition, all the power supply components from the dedicated Division III bus to the pumps, valves, controls, and instrumentation are also considered in this study. The normal power supply to the dedicated Division III bus is considered to be outside the scope of this study; however, a risk-based discussion of the effect of a loss of offsite power on the system is included. The HPCS system is supported by a dedicated^a cooling system consisting of a cooling pump and associated valves and piping. Two plants, Nine Mile Pt. 2 and River Bend, do not have a dedicated HPCS cooling water system. These two plants use the standby service water system to supply HPCS cooling water needs. The dedicated portions of the piping and valves are included in this study; the remainder of the system and the ultimate heat sink are considered outside the scope of this study. The portion of the heating, ventilating, and air-conditioning system directly supporting the HPCS system is also included in this study.

a. The ultimate heat sink for the cooling system is not dedicated to the HPCS system.

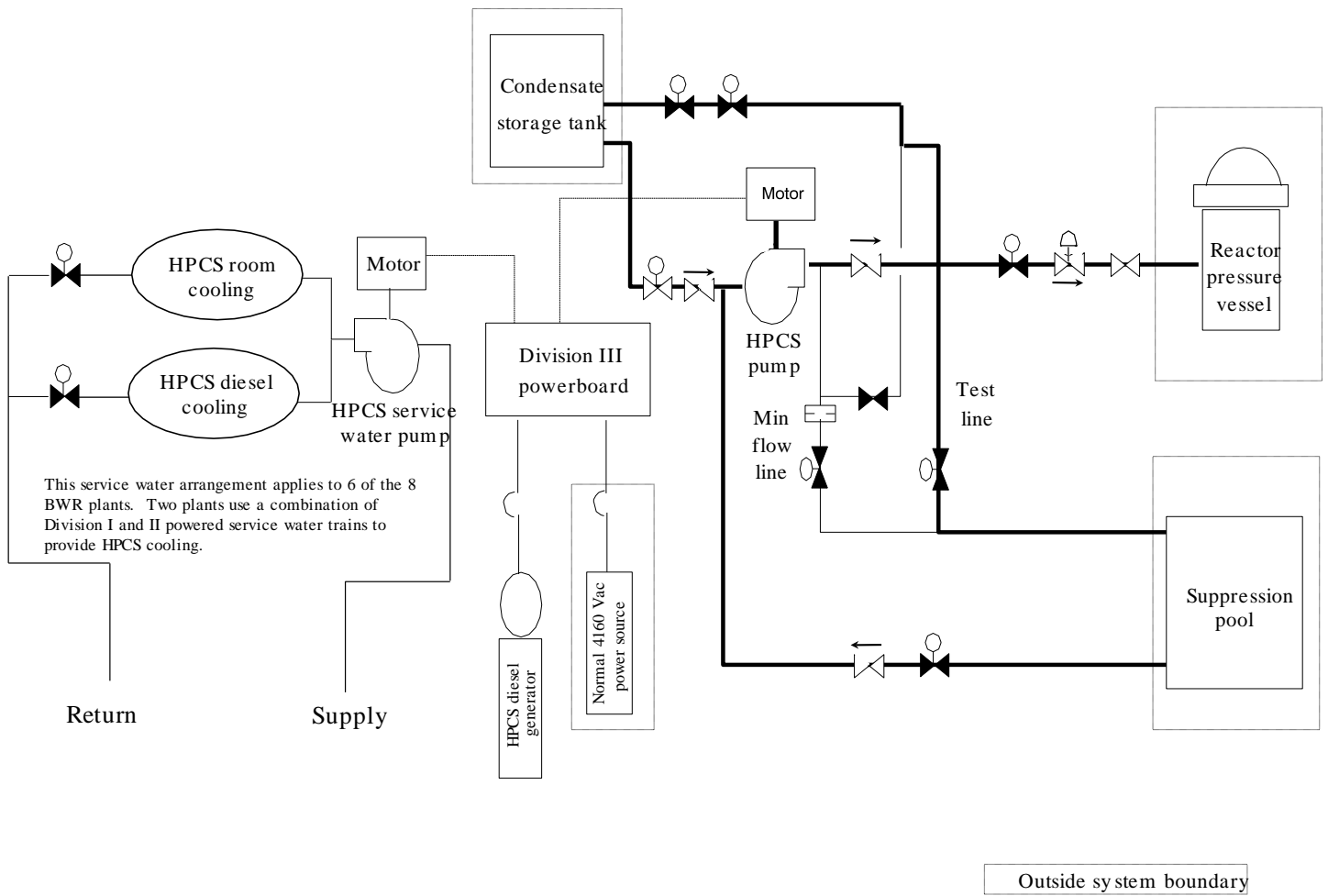

Figure 4. Simplified schematic of the HPCS system.

8. REFERENCES

- [1] United States Nuclear Regulatory Commission, "Component Reliability Data Sheets Update 2015," February 2017. [Online]. Available: <https://nrcoe.inl.gov/resultsdb/publicdocs/AvgPerf/ComponentUR2015.pdf>.
- [2] S. A. Eide, T. E. Wierman, C. D. Gentillon, D. M. Rasmuson and C. L. Atwood, "Industry-Average Performance for Components and Initiating Events at U.S. Commercial Nuclear Power Plants," NUREG/CR-6928, U.S. Nuclear Regulatory Commission, February 2007.
- [3] United States Nuclear Regulatory Commission, "Component Reliability Data Sheets Update 2010," January 2012. [Online]. Available: <https://nrcoe.inl.gov/resultsdb/publicdocs/AvgPerf/ComponentUR2010.pdf>.
- [4] C. D. Gentillon, "Overview and Reference Document for Operational Experience Results and Databases Trending," February 2016. [Online]. Available: <https://nrcoe.inl.gov/resultsdb/publicdocs/Overview-and-Reference.pdf>.